

Lab 05: Artificial Neural Networks

CHEN4011: Advanced modeling and Control

Ranjeet Utikar

2023-09-10

1 Objectives

1. To develop ANN model using MATLAB Neural Net Fitting toolbox.
2. To simulate the ANN model as a soft sensor in Simulink.

2 Problem Statement

A distillation column top product impurity (percentage impurity) is known to be strongly related to one of the tray temperatures and column differential pressure. Figure 1 illustrates the distillation column simulation in Simulink. Note that u_1 denotes the feed flow rate, u_2 the feed heavy component molar fraction, x_1 the tray temperature, x_2 the differential pressure and Y the distillate percentage impurity.

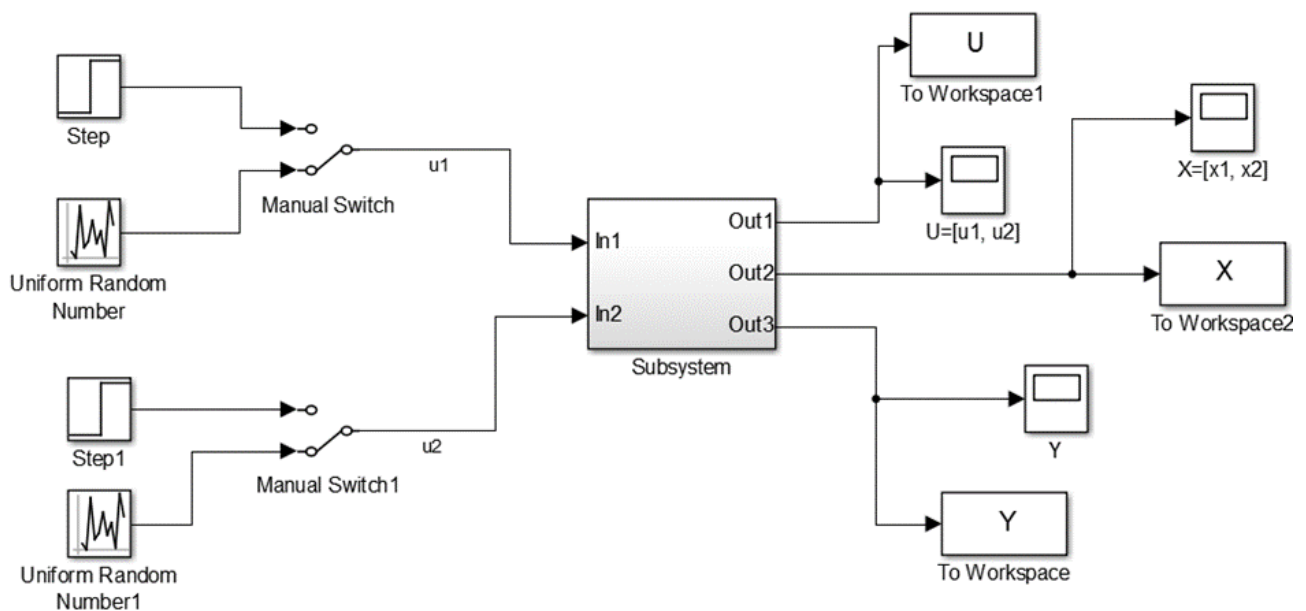

Figure 1: Distillation column distillate product impurity (Y) representation in Simulink.

3 Product purity model

x_1 transfer function (based on u_1):

$$x_1(s) = \frac{1}{3s + 1} \quad (1)$$

x_2 transfer function (based on u_2):

$$x_2(s) = \frac{0.7s - 0.5}{s^2 + s + 1} \quad (2)$$

Relation between x and Y

$$y = 2.5 + 0.9x_1 - 0.3x_2 - 0.1x_1x_2 + 0.05x_1^2 - 0.06x_2^2 \quad (3)$$

You wish to develop an ANN model to predict the distillate impurity. You decide to use uniform random number generator with sampling time of 1 unit to be applied to the feed flow rate and heavy component molar fraction. Additionally, you wish to test the ANN model predictive capability using another set of data generated using step changes applied to the two inputs: 1 unit step up in u_1 at $t = 1$, followed by 1 unit step down in u_2 at $t = 20$, then 1 unit step up in u_2 at $t = 30$ and finally 1 unit step down in u_1 at $t = 65$.

1. Develop an ANN model (Y as a function of x_1 and x_2) using the data generated over the following simulation time:
 - a) 100 units simulation time (ANN 1)
 - b) 200 units simulation time (ANN 2)
2. Implement the ANN models in the Simulink (use the given Simulink model) and perform simulation of the distillate impurity to compare the ANN model prediction with the actual impurity.

4 Report Format

The report should be no more than 5 pages excluding the cover page.

1. Describe your models. For each ANN model (ANN1 and ANN2) above, state the number of hidden layers used, and R^2 in addition to showing the regression plot. You might try different number of hidden layers in order to get the best fitting results. [4 marks]
2. Show your implementation of the ANN models. Show the responses (figures) of the ANN predicted values and the actual impurity when the u_1 and u_2 are subjected to the sequence of step changes mentioned above. [4 marks]
3. Comment on the ANN model prediction accuracy. [2 marks]